

HST

Wideband Precision High Voltage Divider



Very suitable for wideband power measurement at medium voltage inverters, HV discharge lamps, ultrasonic and plasma generators

- Precise measurement up to 20 kV peak voltage
- Frequency range DC to 300 kHz
- Negligible phase error
- One-, two- and three-phase version available
- Difference measuring of floating voltages

Precision High Voltage Dividers for Precision Power Meters

The wideband precision high voltage divider of series HST expand the voltage measuring range of ZES ZIMMER precision power meters LMG for use at nominal voltages over 1000 V. The high voltage inputs are equipped with 2 m leads that are attached to the voltage measured against earth. The open leads can be finished by the customer. The HST3 (resp. HST6/9/12) divides DC, AC or any distorted voltages with very high accuracy by the factor 1000 (resp. 2000 / 3000 / 4000). The divided voltage is available at the buffered low impedance BNC output. To avoid noise interference it is recommended to use shielded cables to the measuring input of the LMG. The HST can be delivered as one-, two- or three-channel version to match the particular measuring task. The one-channel HSTx-1 is used in single ended systems (e.g. ultrasonic applications).

For floating (difference) voltage measuring (e.g. discharge lamps, plasma applications) the two-phase HSTx-2 is best suitable. The difference between the two measuring points can be measured as difference between the output signals of the channels. Typical application fields for the three-channel HSTx-3 are frequency inverter-fed medium voltage drives and voltage harmonics. The high voltage dividers are not suitable to measure on the grid!

Safety

To guarantee a safe measurement you must connect the protective earth terminal of the enclosure with an appropriate earthing point. Here you have to make sure that the earthing conductor has a sufficient cross section, depending on the possible short circuit current of the application. The existing protecting earth connection of the power supply is not dimensioned for this. The appropriate safety instructions are strictly to be observed!

We recommend to use high voltage fuses which are used for voltage transformer protection, and surge arresters.

The high voltage dividers are not suitable to measure on the grid, as lightning strokes, switching operations and similar incidents may induce high transient overvoltages, significantly above the allowed values specified by ZES ZIMMER, and therefore a safety risk for man and equipment exists.

For further safety and application-related information see „HST3, -6, -9, -12 User Manual“.

Measurement principle

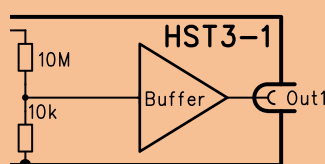

1-channel HST for single-ended voltages

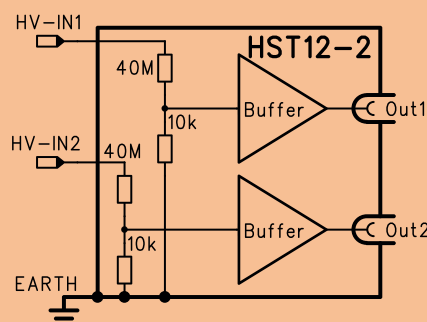

2-channel HST for floating voltages (difference measuring)

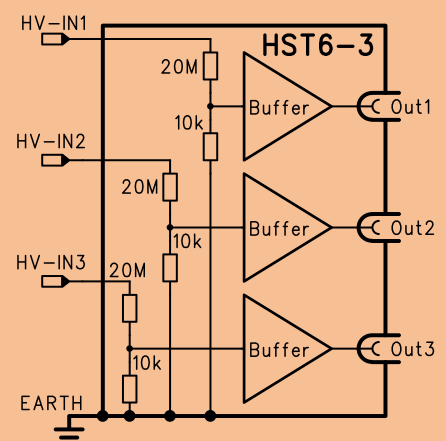

3-channel HST for three-phase systems (inverters)

Wiring of 3-phase HST in 3-phase systems

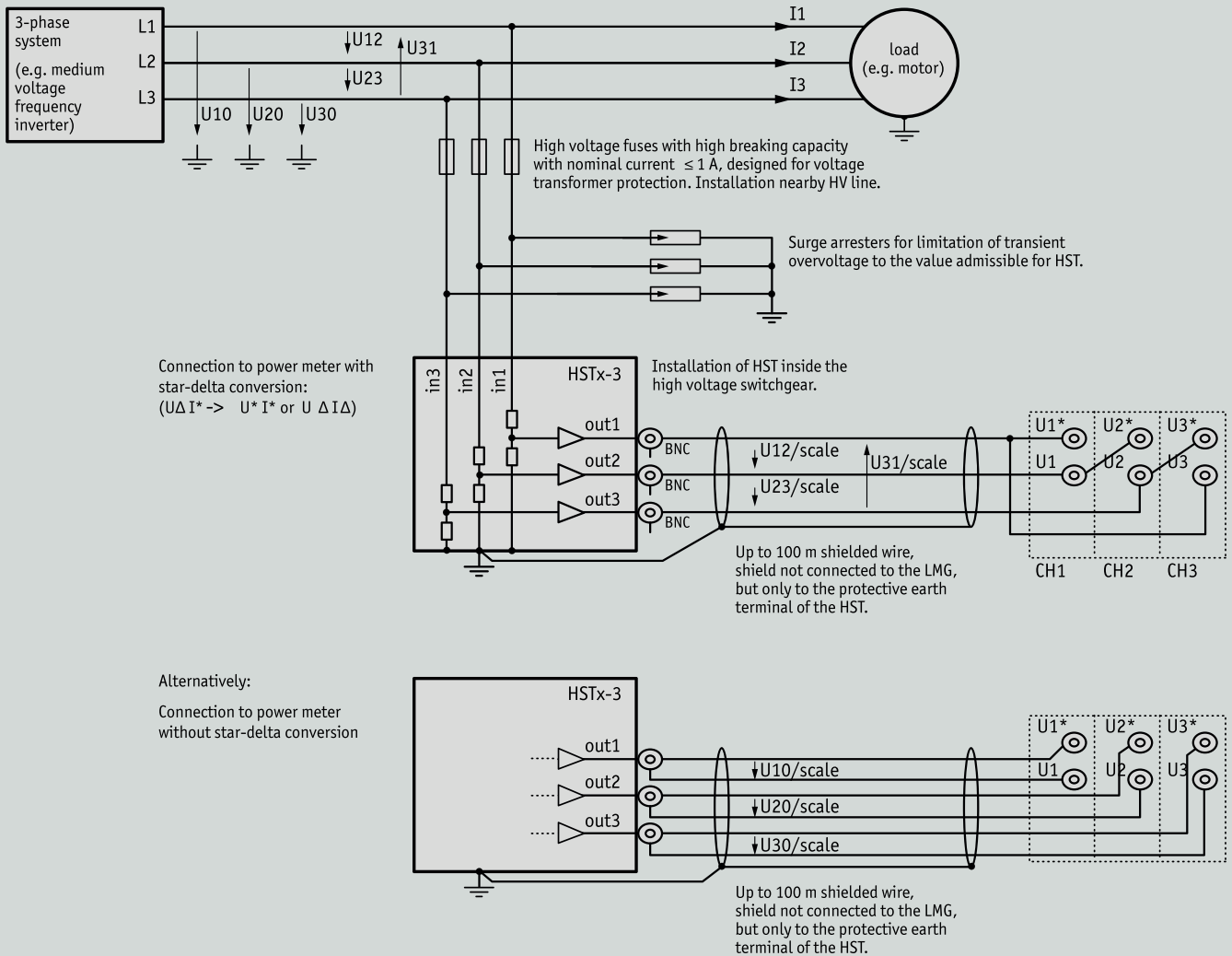

On the high voltage side the HST inputs in1, in2, in3 are connected with lines L1, L2, L3. All voltage measurements have the same reference potential: earth.

The earthed HST can also measure isolated (non-earthed) sources, as these are always bound to earth by their earth capacities.

The low voltages at the measuring outputs out1, out2, out3 can be connected with the precision power meter LMG or other instruments by two different ways:

1. Instruments with internal star-delta conversion are connected as shown in the upper part of the drawing. This has the advantage that existing common mode voltages in the 3-phase system are not measured because of the difference measurement.

2. Instruments without star-delta conversion are connected as shown in the lower part of the drawing. The line voltages with reference potential earth can be tapped directly at the BNC jacks. Here all common mode voltages are captured by the measurement.

Examples for the occurrence of common mode voltages are the DC voltages at complex rectifier circuits and zero-phase systems of fundamental and/or harmonics. By including the common mode voltages in the measurement the trms values of voltage and of apparent power are altered, and the collective sums of trms voltages and apparent power are increased. In both cases the active power is measured correctly.

Technical Data

	Series	HST3			HST6			HST9			HST12		
	no. of channels	1	2	3	1	2	3	1	2	3	1	2	3
	ordering type	HST3 -1	HST3 -2	HST3 -3	HST6 -1	HST6 -2	HST6 -3	HST9 -1	HST9 -2	HST9 -3	HST12 -1	HST12 -2	HST12 -3
Nominal electrical rating of measuring inputs	maximum sine trms voltage for full scale	3.5 kV			7 kV			10.5 kV			14 kV		
	maximum trms input voltage	4.2 kV			8.4 kV			12.6 kV			16.8 kV		
	maximum peak voltage for full scale	5 kV			10 kV			15 kV			20 kV		
	input impedance	10 MΩ 50 pF			20 MΩ 25 pF			30 MΩ 22 pF			40 MΩ 20 pF		
	dividing ratio	1/1000			1/2000			1/3000			1/4000		
	measuring accuracy				dividing ratio			phase error					
	DC				max. ± 0.05%			-					
	0.05 Hz...45 Hz				max. ± 0.1 %			0.06 °					
	45 Hz...65 Hz				max. ± 0.05 %			0.06 °					
65 Hz...2.5 kHz				max. ± 0.1 %			0.2 °						
2.5 kHz...10 kHz				max. ± 0.2 %			0.4 °						
10 kHz...100 kHz				max. ± 0.3 %			0.5 °						
100 kHz...300 kHz; max. 100 pF burden				typ. ± 2 %			2.5 °						
output burden	min. 1 kΩ; max. 1 nF												
Overvoltage capability of high voltage input against earthed case *) voltages in accordance to EN 61010:2010, valid for max. altitude 2000m over sea level	maximum trms voltage*	4.2 kV			8.4 kV			12.6 kV			16.8 kV		
	maximum periodic peak voltage*	5 kV			10 kV			15 kV			20 kV		
	maximum transient overvoltage*	3.8 kV			6.8 kV			8.8 kV			10.2 kV		
	non-repetitive maximum peak voltage*	8.8 kV			16.8 kV			23.8 kV			30.2 kV		
Mechanical	measurement input	one fixed high voltage lead (length 2 m) for each channel, open leads to be finished by customer, earth jack as common reference point											
	signal output	one BNC socket for each channel											
	enclosure	robust aluminium case											
	size (L x W x H)	330 mm x 230 mm x 110 mm						400 mm x 230 mm x 110 mm					
	installation dimension (L x W x H)	490 mm x 230 mm x 110 mm						590 mm x 230 mm x 110 mm					
	weight	approx. 6.1 kg						approx. 7.2 kg					
Other	temperature range	5...40 °C, indoor use only											
	safety class	class I; device must be earthed additionally to PE of mains supply cord!											
	mains supply	85...265 V; 45...65 Hz; ca. 20 VA											

Subject to technical changes, especially to improve the product, at any time without prior notification. Copyright © ZES ZIMMER Electronic Systems GmbH

ZES ZIMMER Electronic Systems GmbH
Pfeiffstraße 12 · D-61440 Oberursel
info@zes.com · +49 6171 88832-0
www.zes.com